

Transformer Bushing Monitoring: The Reference Signal Method

by **Emilio Morales**

+++++



Transformer bushings are one of the most critical components of a transformer. Up to 20% of major failures on high voltage transformers today can be related to bushings. Almost half of these failures result in catastrophic failures like explosions, fire or oil spillage. The cost of these damages and the lost opportunity to deliver energy could be several hundred times higher than the price of a bushing. Even a failing bushing which does not lead to a transformer catastrophic failure can harm people due to burst porcelain insulators, catapulted through the air by the force of the arc of the breakdown.



Emilio Morales attended Nuevo Leon State University in Mexico, receiving his bachelor's degree in Electromechanical Engineering in 1980. He has over 30 years of experience in power transformer design which includes transformers up to 500 MVA and 500 kV, furnace and rectifier transformers and reactors. He is member of the IEEE/PES Transformer Committee, IEC and CIGRE. He previously worked with GE-Prolec, Ohio Transformer, Sunbelt Transformer and Efacec. He joined Qualitrol in June 2012 as a Technical Application Specialist in transformer applications. His focus is to support solutions in comprehensive monitoring for transformer applications.

Experience has shown that there are two main periods when bushings fail. The first period of bushing failures has to do with production/quality related failures which occur once the bushings reach an age of 10 to 13 years. The second period occurs between 20 and 30 years of age, which is considered its normal lifetime. However, it is also true that bushings can fail before they reach 10 years of age, while at the same time there are bushings installed in transformers that are more than 50 years old.

In order to have a reliable monitoring system, the accuracy of the acquisition of the monitored parameters needs to be very high, so that the system can detect the slight changes of the lost angle that occur due to moisture contamination in the bushing core.

The two main health indicators for a bushing are the loss factor ($\tan \delta$ / Power Factor) and the capacitance. While the loss factor is sensitive to almost all bushing faults, the capacitance is an important factor to detect partial breakdowns between capacitive layers and to detect, in combination with the loss factor, contact problems inside the bushing.

Bushing monitoring is aiming to detect incipient faults and give an early warning as well as using the bushings till its real end of life. In order to have a reliable monitoring system, the accuracy of the acquisition of the monitored parameters needs to be very high, so it can detect the slight changes of the lost angle due to moisture contamination in the bushing core.

There are bushing monitoring systems today that are not able to capture these slight, but important changes. Voltage and angle differences between phases as well as different temperatures

aging rates are not considered in the methods where the sister bushings are used as a reference source to assess the condition of a bushing (like the balanced current method). Methods using voltage sources as reference signals from the same phase of the monitored bushing provide the required accuracy. The phase shift between the leakage current signal from the bushing and the voltage from the voltage transformer is measured and corrected by the phase shift offset so the loss factor can be calculated directly. By using a voltage transformer (VT) as reference source, accuracies up to 0.1 mrad in terms of measuring the phase shift can be achieved and small but relevant changes can be detected.

The two main health indicators for a bushing are the loss factor ($\tan \delta$ / Power Factor) and capacitance. While the loss factor is sensitive to almost all bushing faults, capacitance is an important factor to detect partial breakdowns between capacitive layers, and in combination with the loss factor, to detect contact problems inside the bushing.

Failure Statistic

Transformers are one of the most critical components within the electrical network and cannot, once one fails, be exchanged easily by a new one. Often transformer failures cause the inability to deliver energy, have high potential to harm people and can cause environmental disasters. Due to all of these, a high financial impact often is connected to transformer failures.

The old economies like Europe, North America and Japan are especially facing aged key network components.

Continuous monitoring solutions were not used extensively in the past, due to n-1 availability of the main equipment. Furthermore, monitoring solutions were less reliable or not available 10 to 20 years ago. Nevertheless, the condition assessment in the utilities of the old economies was carried out under comprehensive periodic measurements and maintenance programs. Nowadays these utilities are seeking more solutions to operate their costly components till their real end of life. Furthermore, asset exchange programs will be based on the condition of the equipment. Condition monitoring and condition-based maintenance are seen as an important factor to achieve these goals.

In 2012, the CIGRE WG A2.37 released an interim report [1] which shows the statistic on transformer failures (Table 1).

The results show that over all voltage classes, the failure rate is 0.44%, which means, out of approximately 230 transformers, one will fail per year. Besides the preventions of faults or early detection of upcoming faults, the assessment of the remaining life and the health of the equipment is of immense interest, especially for aged equipment. In order to assess the asset health, a combined set of data from the main transformer and its main components needs to be measured/monitored. Besides other components/parts, bushings are one of the main causes of transformer failures, contributing around 20% to the overall transformer major failures, depending on the type of transformer. Bushing failures can lead to catastrophic failures and can be accompanied by environmental disasters or fatal accidents to people. According to a transformer reliability study published in [2], 70% of all transformer fires are caused by bushing failures.

The causes of bushing failures vary from normal aging, moisture, quality issues during manufacturing, repeated thermal and mechanical cycling, transients, and external influences like external flashovers. As a result, a high number of bushing failures develop from partial breakdowns, thermal instabilities or degradations of longitudinal isolation interfaces.

	HIGHEST SYSTEM VOLTAGE (kV)					
FAILURES & POPULATION INFORMATION	69 kV < 100	100 kV < 200	200 kV < 300	300 kV < 500	700 kV	All
Failures	145	212	163	154	11	685
Transformer-Years	15220	48994	47473	41569	959	156186
FAILURE RATE/YEAR	0.95%	0.43%	0.34%	0.37%	1.15%	0.44%

Table 1. Transformer failure statistics [1]

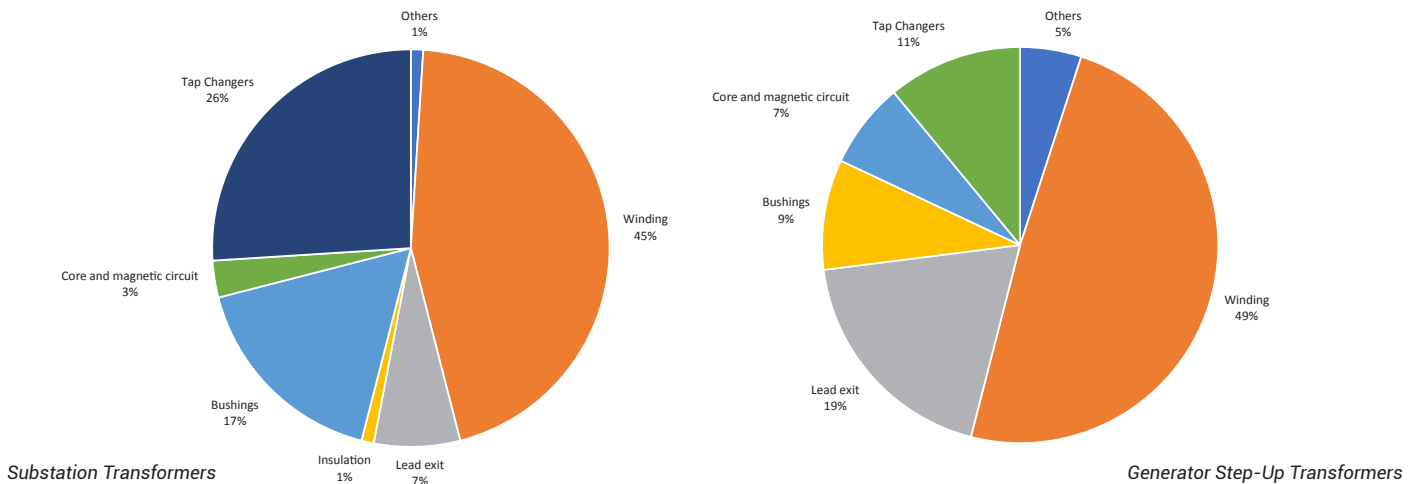

Figure 1. Failed component statistic [1]

To improve transformer reliability the demand of reliable bushing monitoring is increasing throughout the industry.

By using a voltage transformer (VT) as reference source, accuracies up to 0.1 mrad in terms of measuring the phase shift can be achieved and small but relevant changes can be detected

Bushing Monitoring Parameters

The main bushing parameters that are used today for bushing online monitoring are the Power Factor in the IEEE world (or Dissipation Factor in the IEC world) and the bushing main capacitance. These two parameters

can detect different failures in an early stage of its development.

Power Factor

The Power Factor reflects the condition and the health of the insulation itself. It represents the ratio between capacitive and resistive current, which in their summation give the leakage current.

The capacitive current is the result of the capacitive layer design and therewith provide a given value. The resistive current is defined by the resistivity of the insulation material and is a direct parameter of the quality of the insulation system. Each healthy solid and liquid insulation material has a typical resistive current component. An increasing resistive current will indicate a degradation of the insulation system and will increase the angle δ and decrease the angle θ resulting in an increase in Power Factor (see Figure 2).

The Power Factor measurement under online conditions requires high accuracy in order to detect small changes and to guaranty the detection

of increasing moisture content in the insulation system, which is difficult to achieve under online condition. External influences like low frequency magnetic fields, external noise and harmonics as well as the lack of stable reference signal sources are the factors which influence these measurements.

The advantage of online monitoring is that the Power Factor of a bushing can be seen at different temperatures. Offline measurements without additional active heating of the bushing and online monitoring that use the sister bushings as a reference source to assess the condition of a bushing are not able to detect this kind of defects.

Figure 3 shows the behavior of the insulation system with increased moisture content. The accuracy of the measured power factor needs to be very high, considering the power factor difference at 20°C for a wet and dry insulation.

The advantage of online monitoring is that the power factor of a bushing can be seen at different temperatures. Depending on the load of the transformer, the temperature of the bushing will increase or decrease. It can be seen in Figure 3 that the power factor gradient of wet bushings is much higher at higher temperatures than for dry bushings. Offline measurements without additional active heating of the bushing and online monitoring that use the sister bushings as a reference source to assess the condition of a bushing are not able to detect this kind of defects.

Capacitance

As described above for the capacitive current, the capacitance is a parameter which represents the design of the capacitive layers. It will increase, if two or more layers of the electrical field control foils are short circuit (see Figure 4). If only two layers are shorted, the capacitance will increase by a percentage equivalent to the total number of layers. For example, if two out of total 50 layers will be short circuit, the capacitance will increase by 2%

Overview of the Reference Signal Bushing Monitoring Method

One of the newest methods used today for bushing monitoring is the reference signal method, which measures the phase shift of the

leakage current of a bushing and its stable reference signal.

One of the newest methods used today for bushing monitoring is the reference signal method, which measures the phase shift of the leakage current of a bushing and its stable reference signal.

Today, the biggest drawback when it comes to increasing the accuracy in Power Factor and Capacitance monitoring is that the bushings will be compared to each other across the phases and the balances between

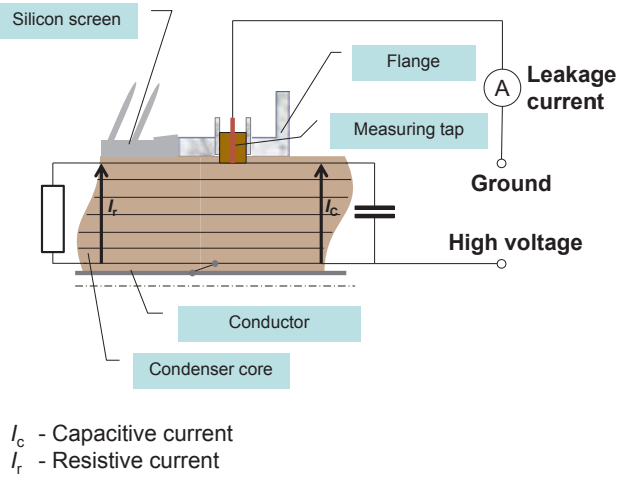
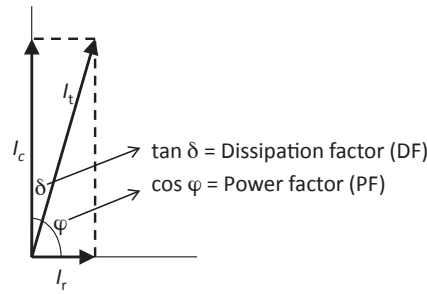

Figure 2. Leakage current and Power Factor



$$\frac{1}{C_{1\text{ total}}} = \frac{1}{C_1} + \frac{1}{C_2} + \frac{1}{C_3} + \frac{1}{C_3} + \frac{1}{C_4} + \frac{1}{C_5} + \frac{1}{C_6} + \frac{1}{C_7} + \frac{1}{C_8} + \frac{1}{C_9} + \frac{1}{C_{10}} + \frac{1}{C_{11}} + \frac{1}{C_{12}} + \frac{1}{C_{13}} + \frac{1}{C_{14}}$$

Figure 4. Bushing series capacitances

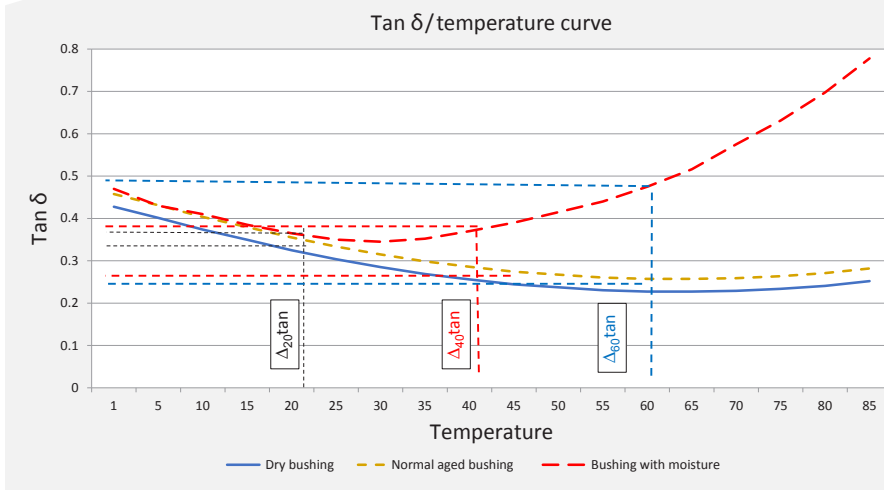

Figure 3. Power factor behavior over temperature due to increased moisture

$$\Delta_{20tan} < \Delta_{40tan} \ll \Delta_{60tan}$$

Valid for wet bushings only!

the phases are not stable and are far from neglectable.

The only approach to overcome this drawback is to find a load independent reference signal source within the same phase as the monitored bushing. A voltage transformer (VT) always has a stable load on its secondary winding. Furthermore, the VTs do not change their transfer behavior according to the load of the network. As pure measurement principle, the phase shift measurement between leakage current and reference signal reduces the needed hardware to a minimum because after digitizing the signal, all signal processing will be done by software algorithms. Figure 5 shows the principles of the reference signal method using VTs from the same phase.

Due to the circumstance that the reference signal from the same phase is used, the achievable accuracy does not depend on phase asymmetries anymore. Existing phase constant shifts from VT, cables etc. are compensated for.

The major challenges using this method are noise reduction or noise elimination and the availability of a stable reference source. The latter is especially not always given.

Sometimes there are only VTs/CVTs on the high voltage side or far away in a separate switchyard (especially in power plants) or VTs/CVTs existing only for one phase (mostly the middle phase). A comparative monitoring in these cases can be applied, which then increases the inaccuracy of the system due to the comparison of different phases as described above. Alternative methods are under development.

Noise elimination or limitation of is one of the major requirements to achieve the necessary accuracy in the phase shift measurement of 0.0057 degree (or 0.1 mrad).

Figure 6 shows a noisy signal before and after signal processing which is illustrating the efficiency of the noise elimination algorithm.

Conclusion

Lab measurements done by bushing manufacturers with real bushings and results from onsite installations show that the accuracy of the power factor values measured/monitored using this method is far better compared to the methods which compare bushings from different phases. The results achieved in the lab showed even better results in stability and accuracy (less than 0.0057 degree).

Extensive tests and first applications of this method for bushing monitoring showed that using the reference method with a reference source from the same phase has the ability to detect small changes in power factor and capacitance changes due to partial breakdowns between two capacitive layers even for voltage levels up to 1 MV installations. Furthermore, this method can also be used for single phase transformers/reactors without limitations.

References

- [1] 1. CIGRE WG A2.37. *Transformer Reliability Survey: Interim Report*. s.l., No. 261, ELECTRA, 2012
- [2] Berg, H.-P. and Fritze, N. *Reliability of Main Transformers*, Salzgitter, Germany, Bundesamt für Strahlenschutz, 2011

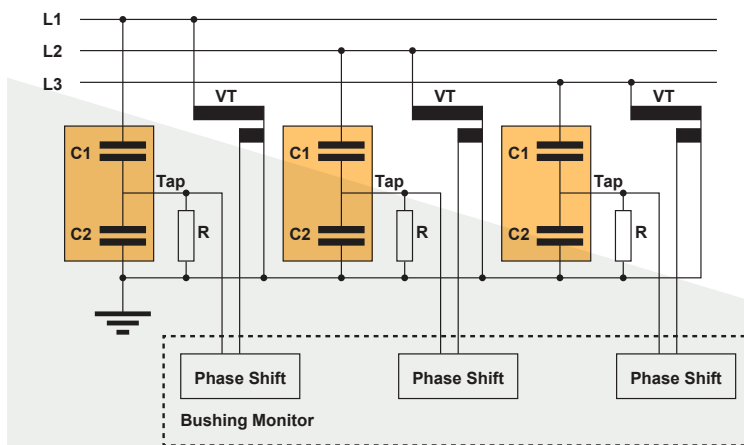

Figure 5. Principle of Reference signal method

Signal processing

- Noise and harmonics need to be eliminated by advanced software algorithms
- The accuracy of the phase measurement is better than 0.1 mrad (0.0057 degree)
- The accuracy enables detecting changes in $\tan \delta$ form, e.g. 0.325% to 0.340%
- It enables early detection of moisture increase, insulation system aging and degradation
- Temperature compensation will be necessary to achieve this accuracy

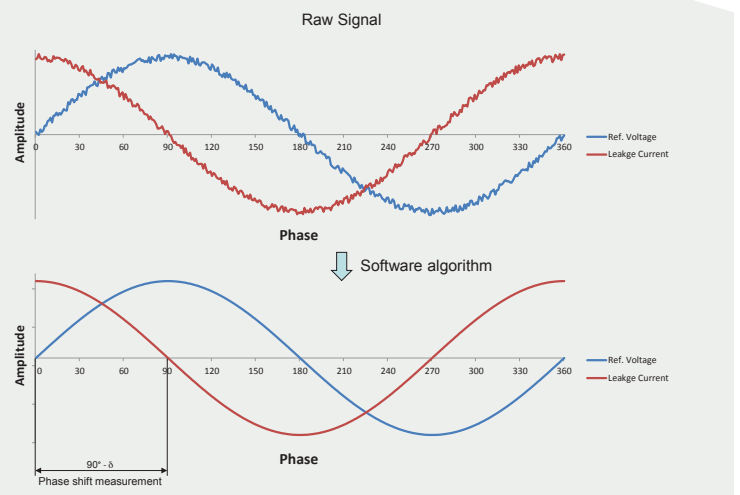

Figure 6. Example of effective noise elimination