

A recent generation of dry type insulation technologies has changed the economics for real-time insulation condition monitoring. This article discusses integrated condition monitoring solutions that can be built into the primary condenser cores of transformer bushings, current transformers and cable accessories (terminations and joints). These solutions include monitoring of capacitive current in the primary condenser core to detect changes in the condenser core C1 capacitance, a new approach for capturing and processing high frequency PD pulse signals in power transformers [1] and HV cable circuits and monitoring accuracy "drift" in revenue-metering current transformers. These factory-installed sensing solutions provide the customer with low-cost real-time condition monitoring options in place of expensive maintenance and field testing programs [1].

Condition monitoring of electrical power equipment has evolved into a significant growth industry offering a wide variety of very sophisticated, multi-parameter solutions. However, with these solutions come the significant costs of managing the large volume of data that is generated from these systems and the ongoing maintenance of the monitoring devices.

This article will describe integrated monitoring systems that can be built in during the manufacture of the equipment and/or components. With this type of system accurate monitoring is ensured due to a high interference shielding design and insensitivity to changes in temperature or frequency. These integrated monitoring systems require no external power source as they are powered directly from the grid connection. Integrated monitoring systems have been developed for



Robert L. Middleton received his degree in electrical engineering from the University of Manitoba, Canada in 1971. He is a registered professional engineer in the Province of British Columbia. He has an extensive background in generation and transmission engineering including quality assurance. He has served on several CSA, CIGRE and IEC working groups and co-authored numerous technical papers. He is presently the Chief of Technology and Engineering for RHM International, a manufacturer of high voltage dry type current transformers, transformer bushings and cable terminations. Prior to joining RHM International he worked over 40 years at two western Canadian provincial electrical utilities.

Integrating Condition Monitoring into the Product: Economical, Accurate and Hassle-free

by **Robert L. Middleton**



the real-time monitoring of the condition of the primary insulation for transformer bushings, current transformers and HV cable terminals, the detection of partial discharge activity in transformers and HV cable circuits and the monitoring of accuracy "drift" in revenue-metering current transformers over their service life.

Integrated monitoring systems that can be built in during the manufacture of the equipment and/or components ensure accurate monitoring due to a high interference shielding design and insensitivity to changes in temperature or frequency.

The Smart RIF® Bushing

The smart RIF® bushing provides a simple and economic alternative for insulation condition monitoring of the bushing. Condenser-graded insulation can be modelled as a series of capacitors separating the conductor and ground. During the process of insulation breakdown screens fail sequentially eventually leading to total breakdown of the insulation. As subsequent screens breakdown the capacitance and capacitance current gradually increases [2]. The smart RIF® bushing is manufactured with a large Cs capacitance ($C_s \gg C_1$) integrated into the condenser core to create a capacitive

voltage divider for accurately measuring these changes (see Figure 1). The two ends of Cs are brought out to a smart measurement terminal installed on the bushing mounting flange where a factory calibrated LED sensor can be plugged in to collect and process the signal (see Figure 2). The LED lights "Green" for normal condition and turns "Red" should a change of capacitance be detected in the condenser core. The LED "Red" indication is only a pre-alarm of a deteriorating condition and allows the utility time to schedule future options for the affected equipment. There is no risk of an imminent failure as lab testing has shown that subsequent failures of capacitive screens will be very slow progressing.

Figure 1. Smart RIF® Bushing Schematic Representation

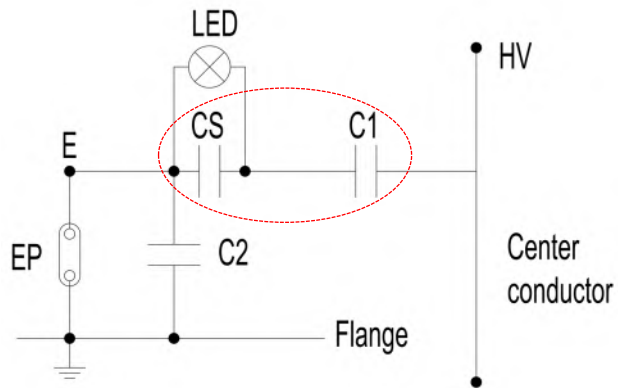

HV – HV terminal connected to grid, E – earth terminal, EP – equipotential plate, C1 – main core insulation capacitance, Cs – signaling capacitance ($C_s \gg C_1$), C2 – test tap to bushing flange insulation capacitance

Figure 2. Smart RIF® Bushing LED Sensor



Photo: RHM International

Integrated monitoring schemes provide economical but accurate real-time monitoring of key condition parameters without having to manage the large volume of data generated by conventional monitoring systems.

Scheme for Detecting PD Activity in a Transformer Using the Smart RIF® Bushing as the Sensor

Field testing for partial discharge in transformers is costly requiring specialized equipment and highly skilled technicians to perform the testing and interpret the data. A more economical solution for detecting PD activity can now be realized by using RIF® bushings equipped with a smart measurement terminal and plug-in PD sensor to couple the discharge pulse current signals coming from the transformer (see Figures 3a and 3b). Depending on the number of RIF® bushings installed on the transformer the scheme can be configured to simultaneously monitor transformer PD signals from up to 9 locations [1] thereby ensuring a very accurate locating of the PD source. The coupled signals from each RIF® bushing are transmitted by a signal cable to a PD monitor installed on the transformer tank wall for data acquisition and processing (see Figure 4). Data for the PD analysis system can be downloaded from the PD monitor, transmitted with optical fibers to a computer in a central control room or transmitted wirelessly.

With this scheme the transformer's entire insulation condition is monitored; it simultaneously monitors the transformer PD condition and the bushings insulation condition.

Monitoring PD Activity in HV Cable Circuits Using Smart RIF® Cable Accessories

RIF® cable accessories (terminals, joints) can also be provided with smart measurement terminals and

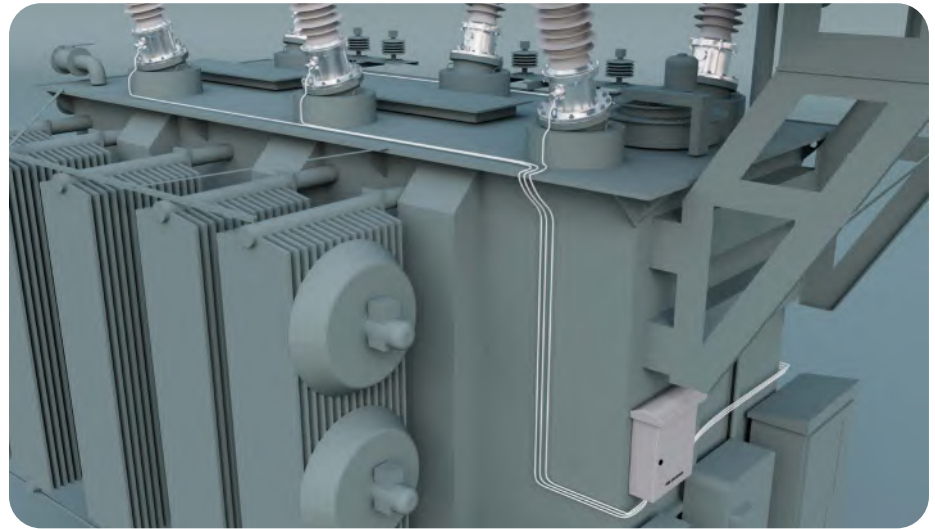

Figure 3a. 3-Ph View Showing RIF® Bushing PD Sensors and Tank Mounted PD Monitor

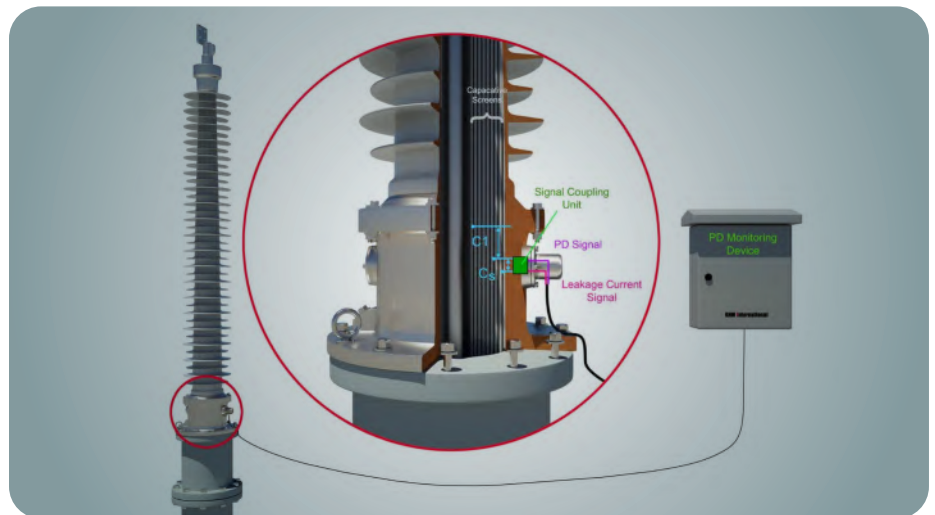

Figure 3b. 1-Ph View Showing RIF® Bushing PD Sensor Details

plug-in PD sensors for detecting PD activity in the terminations and cable circuit (see Figure 5). Partial discharge detection uses the pulse current method and direct coupling provides positive anti-interference performance and high detection

sensitivity. With the smart RIF® cable accessories the insulation condition of the terminations and cable circuit can be monitored 24/7. The working principle is consistent with IEC 60270 and requires no additional sensor installation [3].

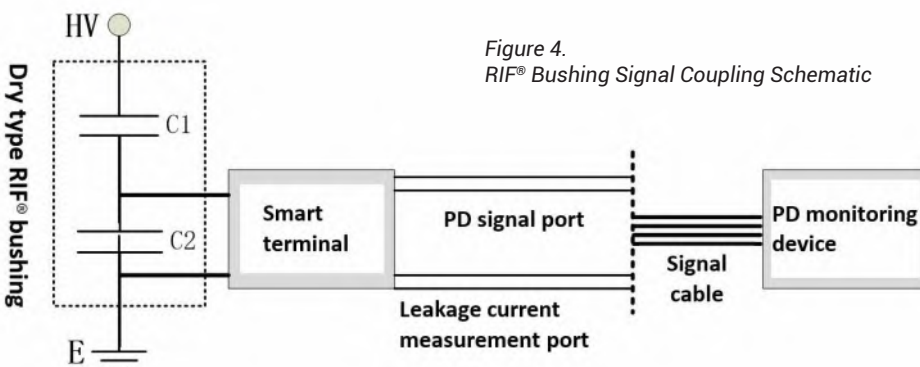
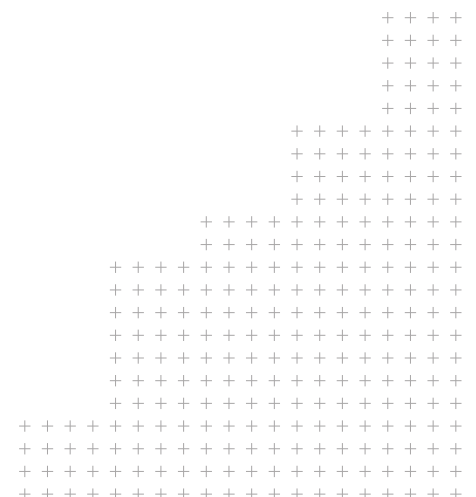

Figure 4. RIF® Bushing Signal Coupling Schematic



Dry Type CT with Real-Time Insulation Condition and Error Monitoring

The current transformer comes equipped with a built-in monitoring device that provides real-time monitoring of the CT's primary insulation condition and the ratio and angle errors for each of the CT's secondary coils (see Figure 6). This is achieved by built-in information collector technology and benchmark coils that are guaranteed not to drift over the CT's service life. This built-in monitoring device needs no external power as its power source comes from the CT itself and is isolated from the HV primary so as not to affect the CT's performance. Finally, standardized data interfaces according to IEC 61850 communication protocol are provided. This monitoring will help to prevent outages due to failing insulation and discover accuracy errors in real-time caused by secondary remanence

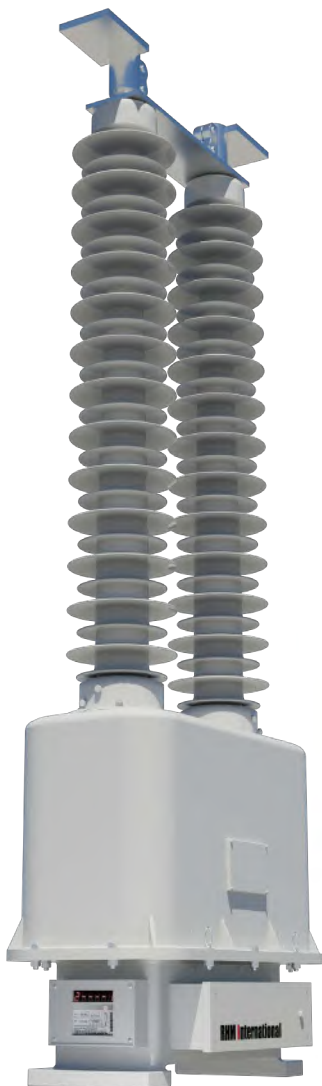

Photo: RHM International

Integrated monitoring systems come factory calibrated and provide a lower cost plug and play installation.

and inter-turn short circuits. It is well known that revenue-metering current transformers once installed usually do not get checked for accuracy "drift" over their service life. This can result in a significant loss of revenue for the utility. Using a current transformer

equipped with this monitoring allows the utility to regularly check the accuracies without having to do expensive off-line testing.

Conclusion

The integrated monitoring schemes discussed in this article provide economical but highly accurate real-time monitoring of key condition parameters without having to manage the large volume of data generated by conventional monitoring systems. These systems come factory calibrated and provide a lower cost plug and play installation.

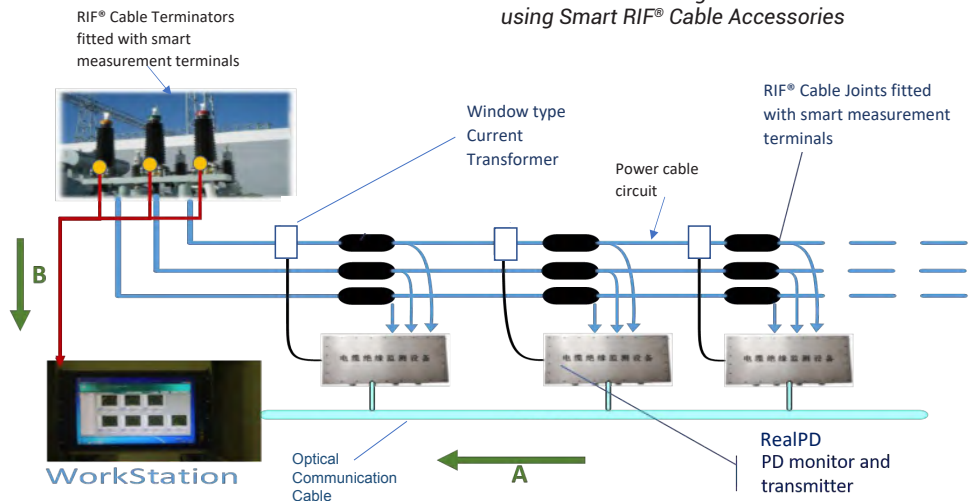

Figure 6. Dry Type CT Equipped with Real-Time Accuracy Display Monitor

Figure 5. Scheme for Detecting in HV Cable Circuits using Smart RIF® Cable Accessories

References

- [1] E. Euvrard, R. Middleton, H. Wang, X. Song, *Innovative Condition Monitoring Solutions Using Integrated Sensing Enabled by a New Generation of Dry Type Insulation Technologies*, IEEE PES T&D New Orleans USA, April 2022
- [2] Tianshui Zhou, XiaoDong Zuo, HaiLiang Wang, Ruzhang Wang, Robert Middleton, Eric Euvrard, *The Development and Operation of Novel Built-in Insulation Monitoring Functions in the Management of HV Bushings*, INMR World Congress Munich Germany, October 2015
- [3] R. Middleton, E. Euvrard, H. Wang, D. Song, Y. Zhao, *Development of a New High Voltage Dry Type Cable Terminator with Optional Integrated Partial Discharge Monitoring*, CIGRE Session 48 (Virtual), Paper B1-102, August/September 2020