

Optimizing Network Reliability and Reducing Customer Interruptions: A Case Study of a UK Distribution Network



The resilience of electrical networks is more important than ever in an era characterised by the acceleration of climate change's effects and a global transition towards low-carbon energy sources. As a basic requirement for modern society to operate efficiently, reliable electrical infrastructure is not merely something to be desired.



David Mills, PhD, CEng, MIET, Director, Net Zero Transition Team - EA Technology, UK
Dr. David Mills is an accomplished electrical engineer with extensive experience in power systems consultancy and net zero transition strategies. With a PhD in Electrical Engineering from the University of Southampton, David leads the Net Zero Transition team at EA Technology. He specializes in developing innovative solutions to integrate renewable energy and enhance grid reliability. His strategic leadership in managing complex projects across the UK, Ireland, and Australia has established him as a key figure in advancing sustainable energy practices and shaping energy network developments to meet future demands.



Waqas Javed, PhD, CEng, SMIEEE, FRSA, FHEA, Senior Consultant & Team Lead, Network Reliability, Net Zero Transition - EA Technology, UK. Dr. Waqas Javed is a distinguished electrical engineer with over a decade of experience in power systems analysis, specializing in smart grid technologies and sustainable energy solutions. Holding a PhD from Glasgow Caledonian University and a post-doctorate from the University of Glasgow, Waqas has deep expertise in dynamic studies, fault analysis, and the application of AI in smart grids which is pivotal in advancing the net zero transition. Currently, as a Senior Consultant and Team Lead at EA Technology, he leads innovative projects that advance the net zero transition, focusing on enhancing grid reliability and integrating advanced technologies into electricity networks. His technical expertise and strategic insights significantly contribute to the development of sustainable energy practices.

Achieving Net Zero presents complex challenges for industries worldwide.

The Net Zero Transition team at EA Technology work in collaboration with a range of clients globally, to provide essential consultancy services to the energy industry.

With multidisciplinary expertise, the team assists businesses across a spectrum of sectors - including electricity Distribution Network Operators, Local Authorities and commercial enterprises. The team

leverages a wealth of expertise and provides tailored insights to support the journey to decarbonisation.

This analysis, insight and innovation ensures our clients are able to understand the impact of emerging low carbon technologies on their system, requirements for electricity network capacity and how to ensure a resilient system for the future.



At EA Technology we are here to support you in the delivering a net zero future for your customers, solving a range of challenges and ensuring you can:

- Drive innovation and create a competitive advantage.
- Increase investor confidence by showcasing commitment to sustainability.
- Deliver the right energy infrastructure to ensure a cost-effective and reliable electricity supply.

Learn more about the Net Zero Transition Team, Scan the QR code below.

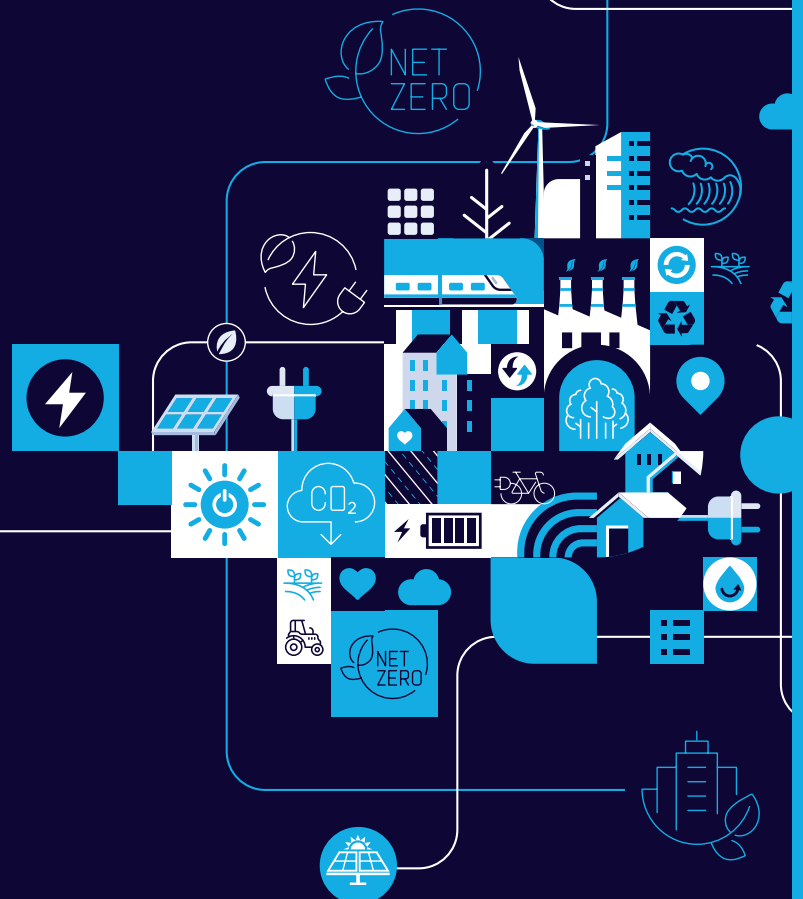

Comparing forecasts with historical faults of a UK distribution network demonstrates an improved solution to identify where asset health improvements can have the greatest impact on reducing customer interruptions. The study explores how future loading and climate change impacts may affect reliability and prioritize solutions, automation schemes and demand flexibility to offer the greatest supply reliability.

The resilience of electrical networks is more important than ever in an era characterised by the acceleration of climate change's effects and a global transition towards low-carbon energy sources. As a basic requirement for modern society to operate efficiently, reliable electrical infrastructure is not merely something to be desired. The increasing frequency of adverse weather events coupled with the intermittent nature of renewable energy sources like solar and wind means that power networks resilience becomes increasingly important [1].

Utility businesses are getting increased focus on minimising customer interruptions. In addition to interfering with routine tasks, power outages have serious negative effects on the economy, impairing corporate operations, stopping industrial processes, and resulting in millions of dollars' worth of lost output. Outages impact public safety, critical services, and even communication networks on a societal level, underscoring the necessity of resilient networks.

A key component of the electricity distribution infrastructure is the medium voltage distribution network, transmitting power before the final step-down transformer to the customers low voltage connection. In the UK this is typically 6.6 or 11 kV. This section of the grid is under significant strain as the demand for power grows due to urbanisation, population expansion, and the electrification of transportation and heating. In addition, increased frequency of extreme weather events like heatwaves, storms, and floods—all of which have the potential to harm network components.

Utilities may reduce customer interruptions (CIs) and customer minutes lost (CMLs) by using predictive maintenance and automation, which allows them to move from reactive to preventative methods. A more robust and flexible distribution network may be achieved by accounting for load increase, equipment wear, and environmental constraints. Through improved system dependability and customer satisfaction, this method better equips utilities to handle future challenges in the 11 kV network.

Background

Proactive infrastructure investment, predictive maintenance plans, and technology advancements to detect, anticipate, and minimize potential issues are necessary to maintain reliability. The 11 kV distribution network must have adaptability to accommodate increasing demand while maintaining resilience and reducing consumer disruptions as the UK moves towards a low-carbon energy future.

Proactive infrastructure investment, predictive maintenance plans, and technology advancements to detect, anticipate, and minimize potential issues are necessary to maintain reliability.

The 11 kV distribution network must have adaptability to accommodate increasing demand while maintaining resilience and reducing consumer disruptions as the UK moves towards a low-carbon energy future.

In GB, the dependability of power distribution networks is evaluated using key performance indicators such as customer interruptions (CIs) and customer minutes lost (CMLs) [2] [3]. These measurements are essential for comprehending network performance and promoting changes to reduce interruptions with the distribution networks receiving regulatory incentives for their improvement.

The two globally recognized indices, SAIFI (System Average Interruption Frequency Index) and SAIDI (System Average Interruption Duration Index), are frequently used to convey these metrics [4]:

SAIFI determines the average number of outages per customer, indicating the frequency of disruptions, whereas SAIDI evaluates the average total time consumers encounter interruptions, usually in minutes or hours, representing how well the network recovers from failures. SAIDI and SAIFI together offer a thorough understanding of network resiliency.

Methodology

The case study is carried out to investigate the potential reliability challenges for a set of 11 kV feeders in UK network. The feeders are modelled in the EA Technology, Target Model® (hereafter known as Target)

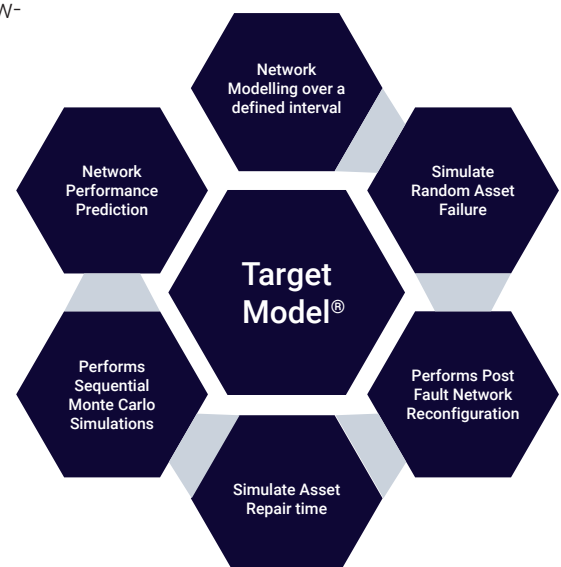

Figure 1:
Target Model Capability

which has the capability to simulate various network conditions depending on the failure rates of the electrical assets. Target performs the reliability analysis by also finding the optimum location for system automation to improve network's reliability (Figure 1).

Network Feeders Data

Two random feeders' data is established similar to the UK distribution

Network named Feeder X and Feeder Y. Feeders data for modelling is presented in Table 1 and Table 2.

To enable the modelling evaluation, load attached to each feeder requires load profile where each customer is assigned a load profile with 48 half-hour demand values.

Asset Failure Rates

Determining failure rates at individual assets, feeder, or network-wide granularity is crucial for asset failure analysis. Increased granularity improving accuracy but requiring more historic failure and condition data to inform correctly.

By concentrating on the most important assets and feeder portions where failure rates have the greatest potential impact, this enables more informed decision-making and increases network resilience.

Results

In this analysis, reliability metrics are quoted in number of customer interruptions (CI) per year and customer minutes lost (CML) per year.

Total CI = \sum (Substation Interruptions x No. of customer supplied) [5] (1)

Total CML = \sum (Substation outage in minutes x No. of customer supplied) [5] (2)

Target Model® Reliability Analysis for Feeder – X

The reliability results forecast by Target for feeder X are summarised in Table 3 before any further actions are taken to enhance customer reliability outcomes.

Optimum Switch Placement Analysis for Feeder – X

There are five normally closed switches being used in Feeder -X for substations 1, 3, and 5, as can be observed in Figure 2. However, there is no switch between connection point C and the primary substation. This means may lead to total outage of substation 2 (losing supply to all the customers for SS-2) in case when

Table 1:
Feeders Data

Feeder Name	Distribution Substation Representation	No. of Distribution Substations (11/0.415) kV	Distribution Transformer Type	Overhead Lines (OHL)	Underground Cables (UGC)	No. of Switches
X	< 10	4	Ground Mounted	0	1.04 km	6
Y	>100	109	Pole Mounted	44.8 km	2.26 km	103
		12	Ground Mounted			

Table 2:
Distribution Feeder Discrimination

Feeder	%age OHL	%UGC	%age Pole Mounted Tx.	%age of Ground Mounted Tx.	No. of Customers	Normally Open Switches
X	0	100	0	100	437	1
Y	95	5	90	10	881	4

Table 3:
Reliability Analysis for Feeder - X

Elements	Value	Units
Total no. of Substations	4	Count
Total no. of customers	437	Count
Total CI per year	17.7	Count
Total CML per year	5897	Minutes
Relevant Substation for worst affected customers	SS-3	Name of substation
Relevant Substation having longer CMLs	SS-2	Name of substation
Number of faults per year	0.04	
SAIFI	0.04	
SAIDI	14.52	





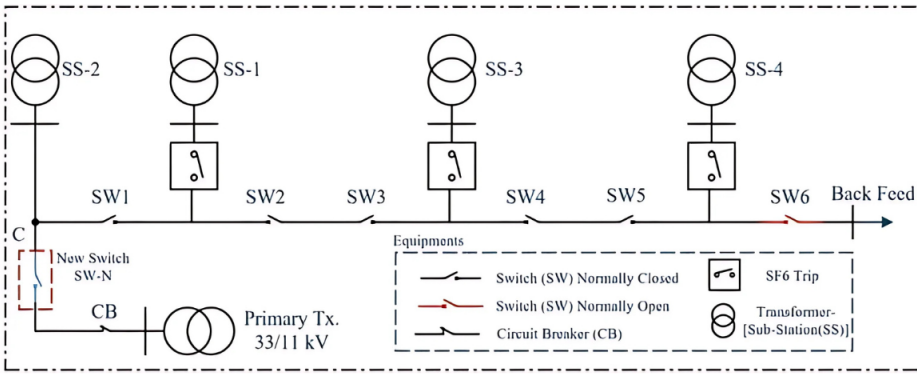

Figure 2:
Feeder - X with Switch Enforcement

fault arises on the line coming from primary transformer.

Hence, a switch has been placed on the line as shown in Figure 2 which will isolate the fault on that line by operating the circuit breaker of the primary transformer. In this case, the supply to SS-2 can be maintained from the back feed side of the network.

Figure 3 demonstrates clearly that by adding a switch at the specified location reduces the CMLs significantly for substation-2 (SS-2).

This also leads to the reduction in SAIDI values for SS-2.

Target Model® Reliability Analysis for Feeder – Y

For feeder Y, Target estimated the reliability metrics as presented in Table 4.

Target simulations identified the assets which are contributing the most towards the outages by calculating the CIs and CMLs for feeder – Y. This helps to identify the specific lines which lead to the maximum number of customers lost if that line fails. Figure 4 and Figure 5 represents the CIs and CMLs respectively sorted by line ID.

Network planners can then evaluate

whether intervention to one of these circuits can increase their customers' supply reliability by combining these two figures. For instance, taking asset repair, network expansion, or network reconfiguration into consideration. All of these are intended to lessen the likelihood or impact of asset failure on customer reliability. For example, Line 47 contributes the largest number of CMLs which allows to plan asset replacement in advance to minimise the impact.

Furthermore, from Figures 4 and 5, it can be observed that Line 237 identified as the common contributor towards high CIs and CMLs in the network. Hence, this takes the higher priority for Line 237 to be considered for improvement. In this network, Line 237 is an overhead line running across several agricultural fields supplying a small settlement. In this instance, by reducing the probability of failure (PoF) of the line assuming that some upgrade may be considered from the planning engineer. To determine the efficacy and timing of any action, all of these choices are simulated while accounting for variations in asset health, consumer demand, and weather patterns.

Simulation results after the Line 237 upgrade, shows the level of CIs and CML improvement for the asset.

Total CMLs Per Year on Different Substations

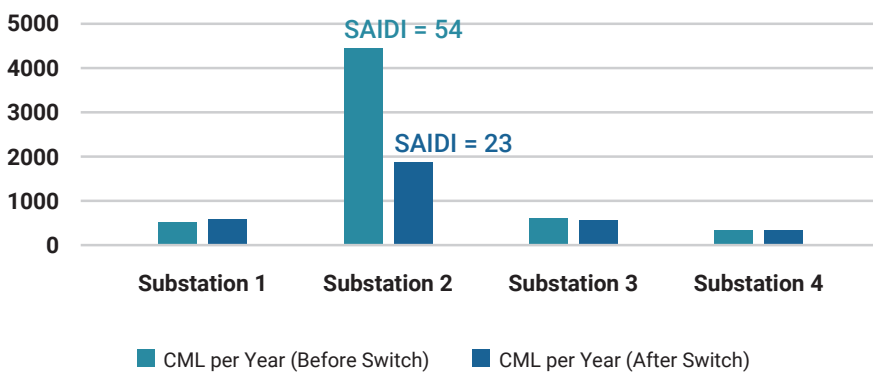
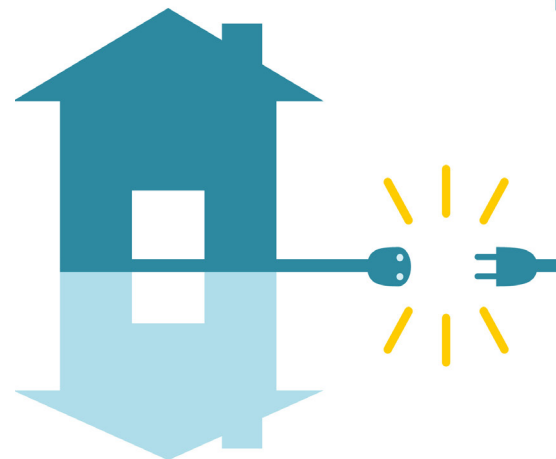

Figure 3:
Customer Minutes Lost (CMLs) for Feeder - X

Table 4:
Reliability Analysis for Feeder - Y

Elements	Value	Units
Total no. of Substations	121	Count
Total no. of customers	881	Count
Total CI per year	3091	Count
Total CML per year	345,575	Minutes



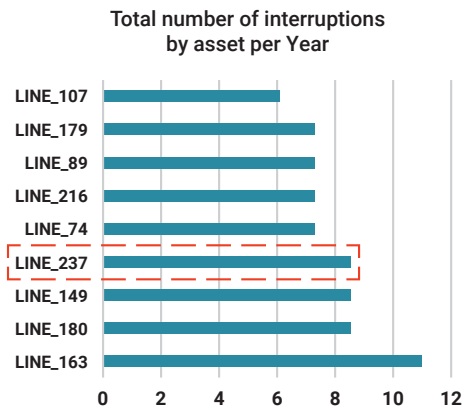

Figure 4: CI Contribution by Asset

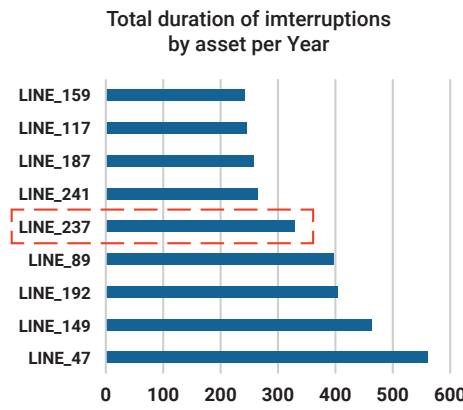

Figure 5: CML Contribution by Asset

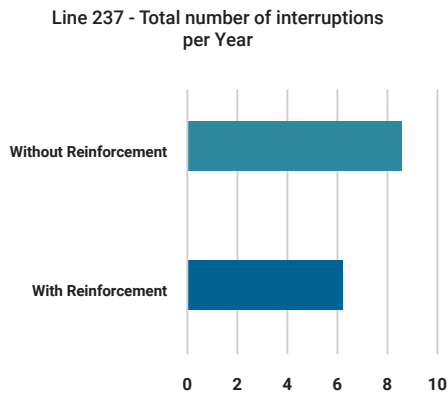

Figure 6: CI for Line_237

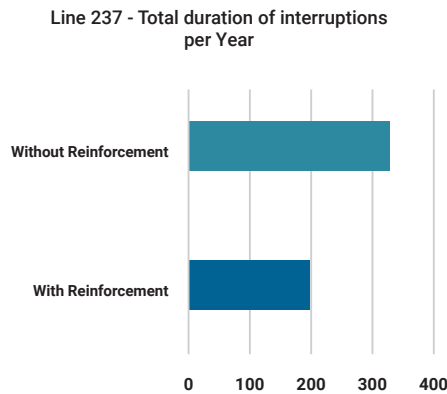

Figure 7: CML for Line_237

Conclusion and Analysis

This study has shown how network operators may better forecast the supply reliability that their customers encounter through combining historic failure data, changes in asset health and future demand on electricity distribution networks. This has enabled distribution networks in the UK to identify priority areas for network reinforcement and opportunities to introduce automation for further reliability improvements.

An examination of a simple feeder (X) demonstrated how the addition of a new switch might dramatically reduce the duration of customer interruptions (CML). This offers a useful tool to network operators looking to cost-effectively prioritise network automation to improve customer supplies.

In the study for a more complex feeder (Y), the study showed how impact of future asset health conditions can be mitigated. Hence, this investigation shows how each asset influences future CIs and CMLs, giving the network operator the ability to prioritise circuits for repair or replacement.

References

- [1] N. G. E. Transmission, "Moving toward Net Zero," National Grid UK, 2023. [Online]. Available: <https://www.nationalgrid.com>. [Accessed September 2024].
- [2] J. Adams and A. K. Parlikad, "Dynamic maintenance based on criticality in electricity network," in Asset Management Conference 2015, London, 2015.
- [3] E. U. Rehman and N. C. Nair, "Resilience based Criticality Analysis for Seismic Performance Assessment of Underground Cables," in TENCON 2021 - 2021 IEEE Region 10 Conference (TENCON), Auckland, New Zealand, 2021.
- [4] Y. K. Bichpuriya, P. V. Navalkar and S. A. Soman, "Benchmarking of Reliability Indices for Electricity Distribution Utilities: Approach and Discussion," in IET Conference on Reliability of Transmission and Distribution Networks, 2011.
- [5] Ofgem, B. P. Internaional and M. M. Limited, "Quality of Service Incentive Scheme Audit of Interruptions Reporting 2009/10," British Power International, United Kingdom, 2011.

